

MONTAGEANLEITUNG

ASSEMBLY INSTRUCTIONS

NOTICE DE MONTAGE

MONTAGEHANDLEIDING

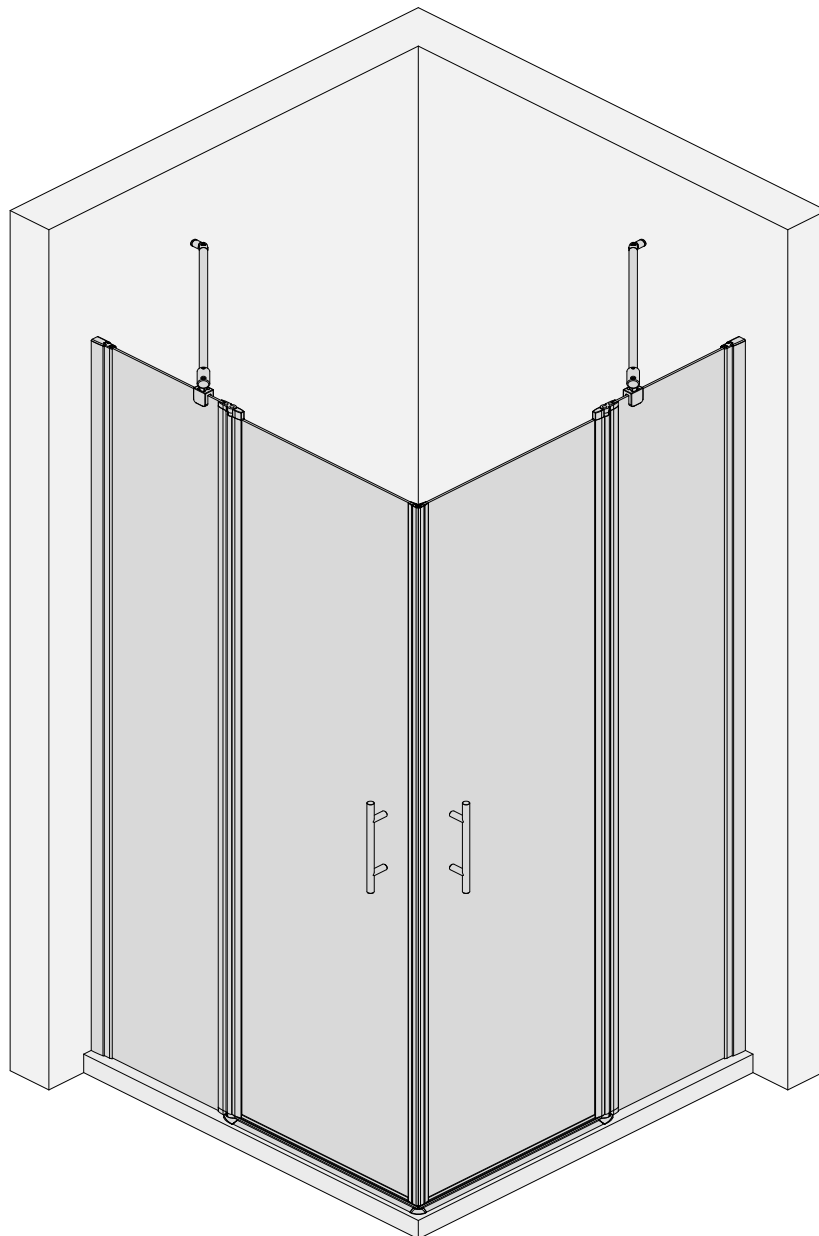



SICHERHEITSHINWEISE / SAFETY INSTRUCTIONS CONSEILS DE SÉCURITÉ / VEILIGHEIDSAANWIJZINGEN



de Glaskanten schützen

en Protect glass edges

fr Protégez les bords du verre

nl Glasranden beschermen



de Schutzbrille tragen

en Wear safety goggles

fr Portez des lunettes de protection

nl Veiligheidsbril dragen

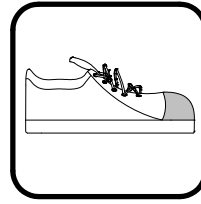

de Sicherheitsschuhe tragen

en Wear safety shoes

fr Portez des chaussures de sécurité

nl Veiligheidsschoenen dragen

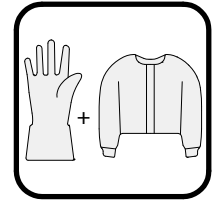

de Lange Handschuhe und langärmelige Kleidung tragen

en Wear long gloves and long-sleeved clothing

fr Portez des gants longs et des vêtements à manches longues

nl Draag lange handschoenen en kleding met lange mouwen

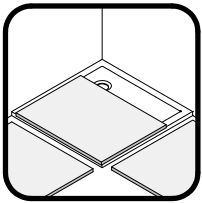

de Decken im Arbeitsbereich und dessen Umfeld auslegen

en Cover the shower tray and its area completely

fr Couvrez complètement le bac de douche et ses environs

nl Dekens op de douchebak en de omgeving leggen

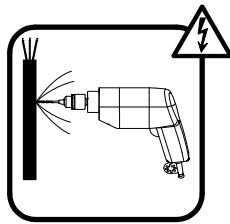

de Über die Lage der Stromleitung informieren

en Get information about the location of the power line

fr Informez-vous sur l'emplacement de la ligne électrique

nl Informeren over de locatie van de hoogspanningslijn

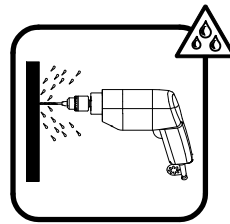

de Über die Lage der Wasserleitung informieren

en Get information about the location of the water pipe

fr Informez-vous sur l'emplacement de la ligne d'eau

nl Informeren over de locatie van de waterleiding



de Empfohlene Montage mit 2 Personen.

en Assembly recommended with 2 persons

fr Montage recommandé avec 2 personnes

nl Aanbevolen montage met 2 personen

HINWEIS / NOTE / NOTE / NOOT

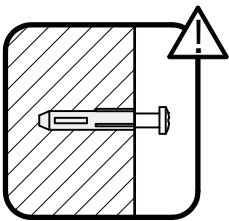

de Vor der Montage die Beschaffenheit des Mauerwerks überprüfen. Gegebenenfalls ist das im Lieferumfang enthaltene Befestigungsmaterial nicht für die Befestigung geeignet.

en Check the condition of the masonry before installation. If applicable, the fixing material included in the scope of delivery is not suitable for mounting.

fr Vérifiez l'état de la maçonnerie avant le montage. Le cas échéant, le matériel d'approvisionnement compris dans la livraison n'est pas adapté à la fixation.

nl Controleer de toestand van het metselwerk voor de installatie. Indien gewenst is het bij de levering inbegrepen bevestigingsmateriaal niet geschikt voor montage.

de Die Aufstellfläche der Duschkabine muss eben sein.

en The installation surface of the shower enclosure must be level.

fr La surface d'installation de la cabine de douche doit être plane.

nl Het montagevlak van de douchewand moet waterpas zijn.

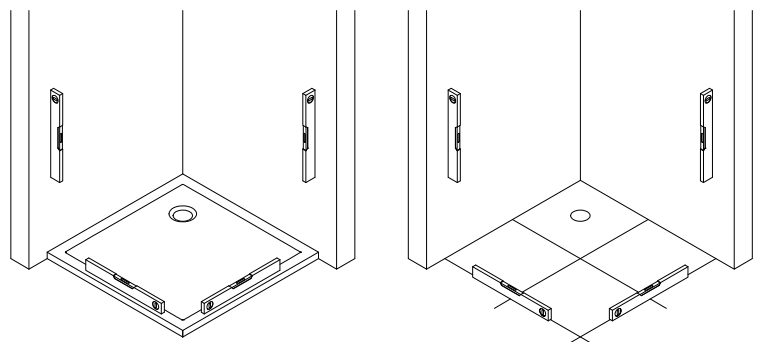

MAßE / DIMENSIONS / DIMENSIONS / AFMETINGEN

- de** Prüfen, ob die gemessenen Maße innerhalb der Tabellenwerte (A, B bzw. C, D) liegen, damit die Duschkabine problemlos, anhand der Montageanleitung aufgebaut werden kann.
- en** Check whether the measured dimensions are within the table values (A, B or C, D), so that the shower enclosure can be assembled without any problems using the assembly instructions.
- fr** Vérifier que les dimensions mesurées se situent dans les valeurs du tableau (A, B ou C, D), afin que la cabine de douche puisse être montée sans problèmes en suivant les instructions de montage.
- nl** Controleer of de gemeten afmetingen binnen de tabelwaarden (A, B of C, D) vallen, zodat de douchewand zonder problemen met behulp van de montagehandleiding kan worden gemonteerd.

de Montage auf Duschwanne

(Maße des installierten Duschbeckens)

en Mounting on shower tray

(Dimensions of the installed tray)

fr Montage sur receveur de douche

(Dimensions du mur au bord d'extérieur du receveur)

nl Montage op douchebak

(Afmetingen van de ingebouwde douchebak)

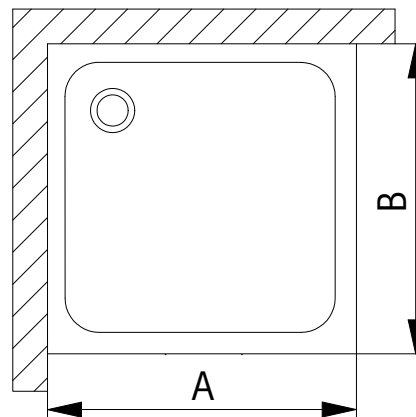

Duschwanne / shower tray receveur de douche / douchebak	A	B
750 mm	735 - 753 mm	735 - 753 mm
800 mm	785 - 803 mm	785 - 803 mm
900 mm	885 - 903 mm	885 - 903 mm
1000 mm	985 - 1003 mm	985 - 1003 mm

oder / or / ou / of

de Montage ohne Duschwanne

(Abmessungen des Produktes) (Glasmitte)

en Mounting without shower tray

(Mounting on tile) (Middle of the glass)

fr Montage sans receveur de douche

(Montage sur carrelage) (Dimension mi-verre)

nl Montage zonder douchebak

(Montage op tegel) (midden van het glas)

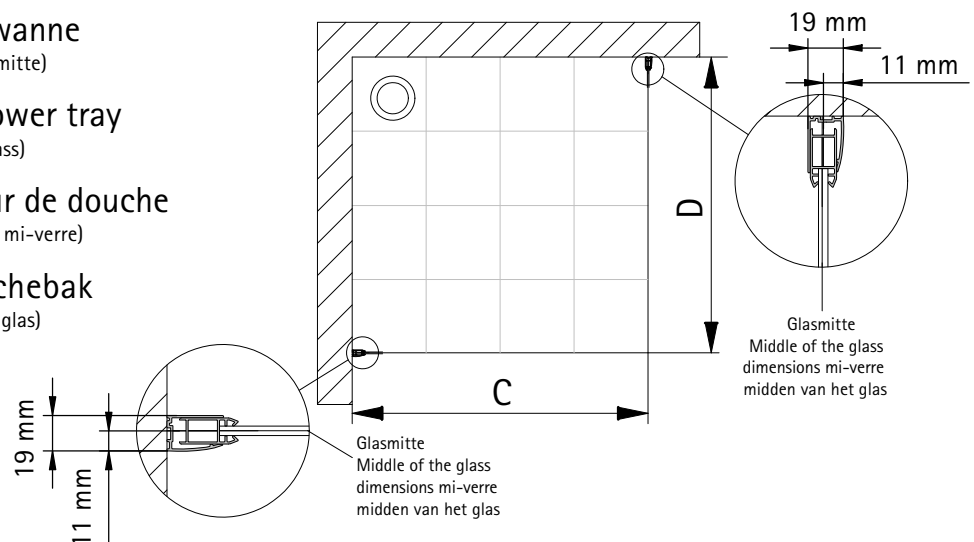

Version / Versie	C	D
750 mm	704 - 722 mm	704 - 722 mm
800 mm	754 - 772 mm	754 - 772 mm
900 mm	854 - 872 mm	854 - 872 mm
1000 mm	954 - 972 mm	954 - 972 mm

1997-3

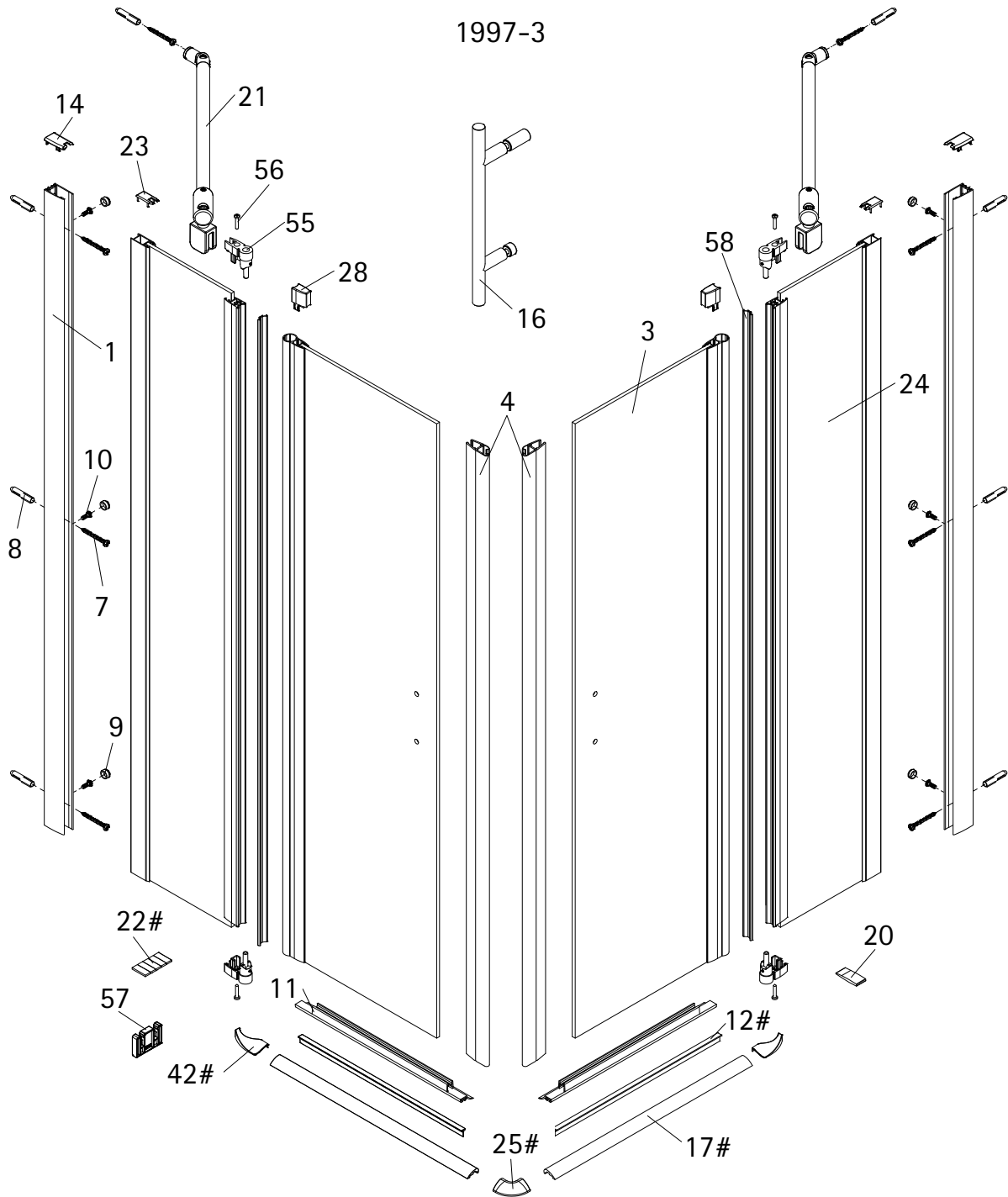

Pos.	Bezeichnung	Ersatzteil-Nr.	Preis	Pos.	Bezeichnung	Ersatzteil-Nr.	Preis
1	2x Wandanschlussprofil	E100230-4	Stück 91,10 €	21	2x Stabilisationsbügel, komplett	E100320	Stück 49,20 €
3	2x Türelement rechts/ links			22#	1x Klebestreifen		
4	2x Magnet	E100055-90-5	Set 57,60 €	23	2x Abdeckkappe		
7*	6x Schraube 4,2 x 45 mm			24	2x Festelement rechts/ links		
8*	6x Dübel S6			25#	1x Wasserleistenendkappe (inkl. Pos. 42)	E100211-24	Set 10,40 €
9*	6x Abdeckkappe für Kappenschraube			28*	2x Kappe für Drehlager		
10*	6x Kappenschraube 3,5 x 9,5 mm			42#	2x Wasserleistenendkappe		
11	2x Wasserabweisprofil	E100058-5	Stück 24,10 €	55	4x Drehlager (inkl. Pos. 28, 56)	E100082-5	Set pro Seite 33,50 €
12#	2x Einschubdichtung	E100067-145-10	Stück 15,70 €	56*	4x Schraube 3,5 x 19 mm		
14	2x Abdeckkappe (inkl. Pos. 23)	E32205-2	Set 12,50 €	57	4x Montagehilfe	E100201-7	Set 12,60 €
16	2x Stangengriff klein	E100140-17	Stück 34,50 €	58	2x Innendichtung	E100070-2	Stück 26,10 €
17#	2x Wasserleiste (inkl. Pos. 22)	E100050-2	Set 36,70 €				
20	1x Silikonkeil (6 Stück)	E100203	Set 17,80 €				
					* Montagezubehör	E32200-2	17,80 €
					# optional		

de Geben Sie bei farbigen Ersatzteilen den Farbcode mit an: 01 - aluminium | 04 - weiß | 41 - chrom | 68 - schwarz

en Please state the colour code for coloured spare parts: 01 - aluminium | 04 - white | 41 - chrome | 68 - black

fr Veuillez indiquer le code couleur pour les pièces de rechange colorées : 01 - aluminium | 04 - blanc | 41 - chromé | 68 - noir

nl Gelieve de kleurcode voor gekleurde onderdelen te vermelden: 01 - aluminium | 04 - wit | 41 - chrom | 68 - zwart

BENÖTIGTES WERKZEUG / TOOLS NEEDED
OUTILLAGE NÉCESSAIRE / BENODIGD WERKTUIG

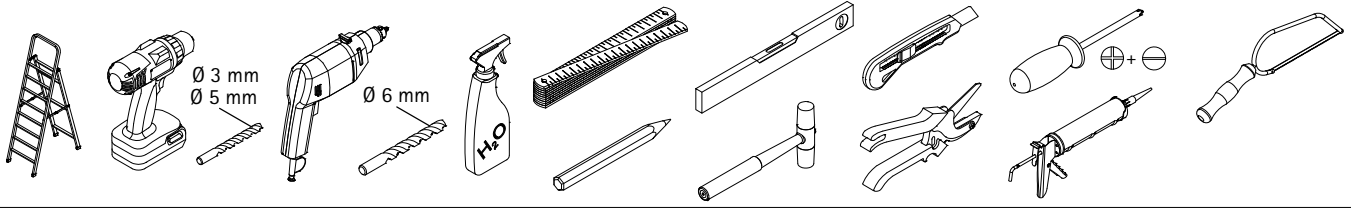

MONTAGE / ASSEMBLY / ASSEMBLAGE / ASSEMBLAGE

1

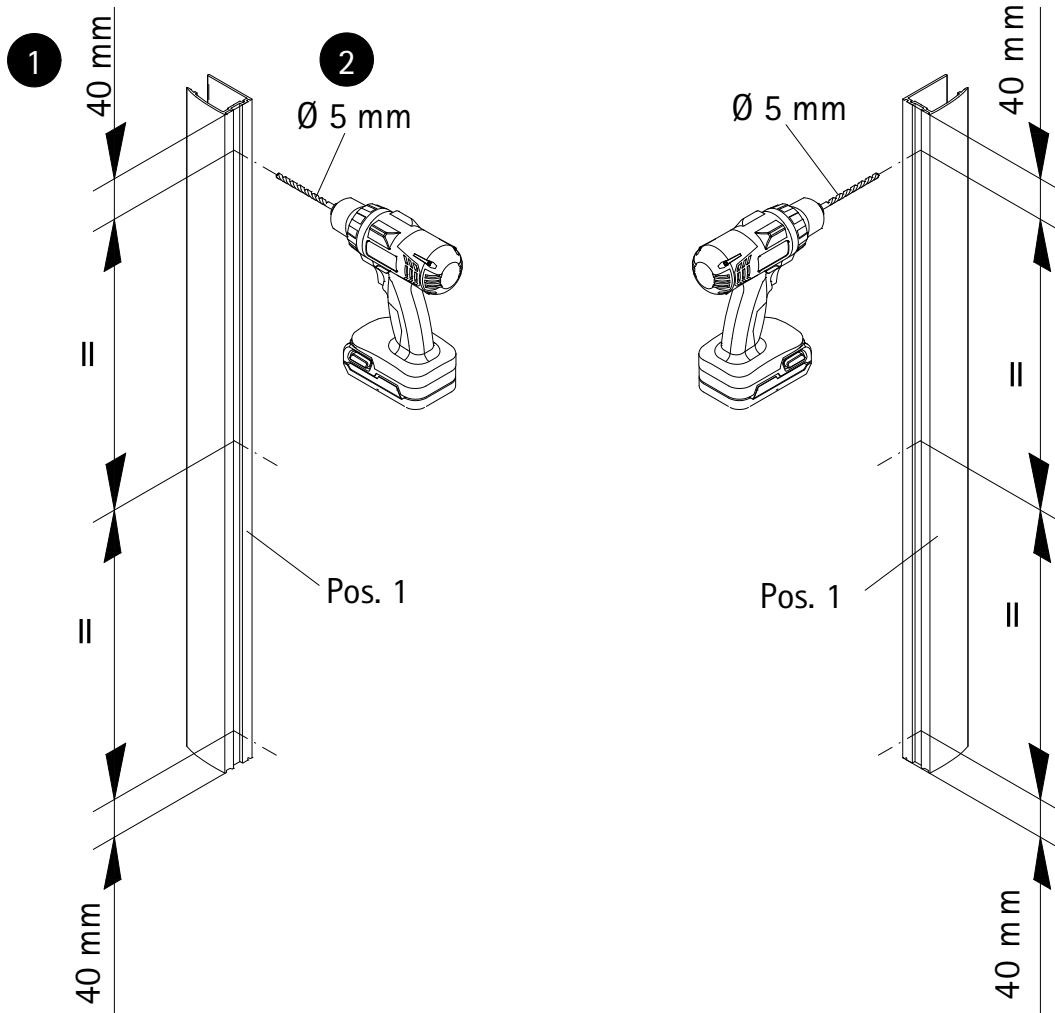

2

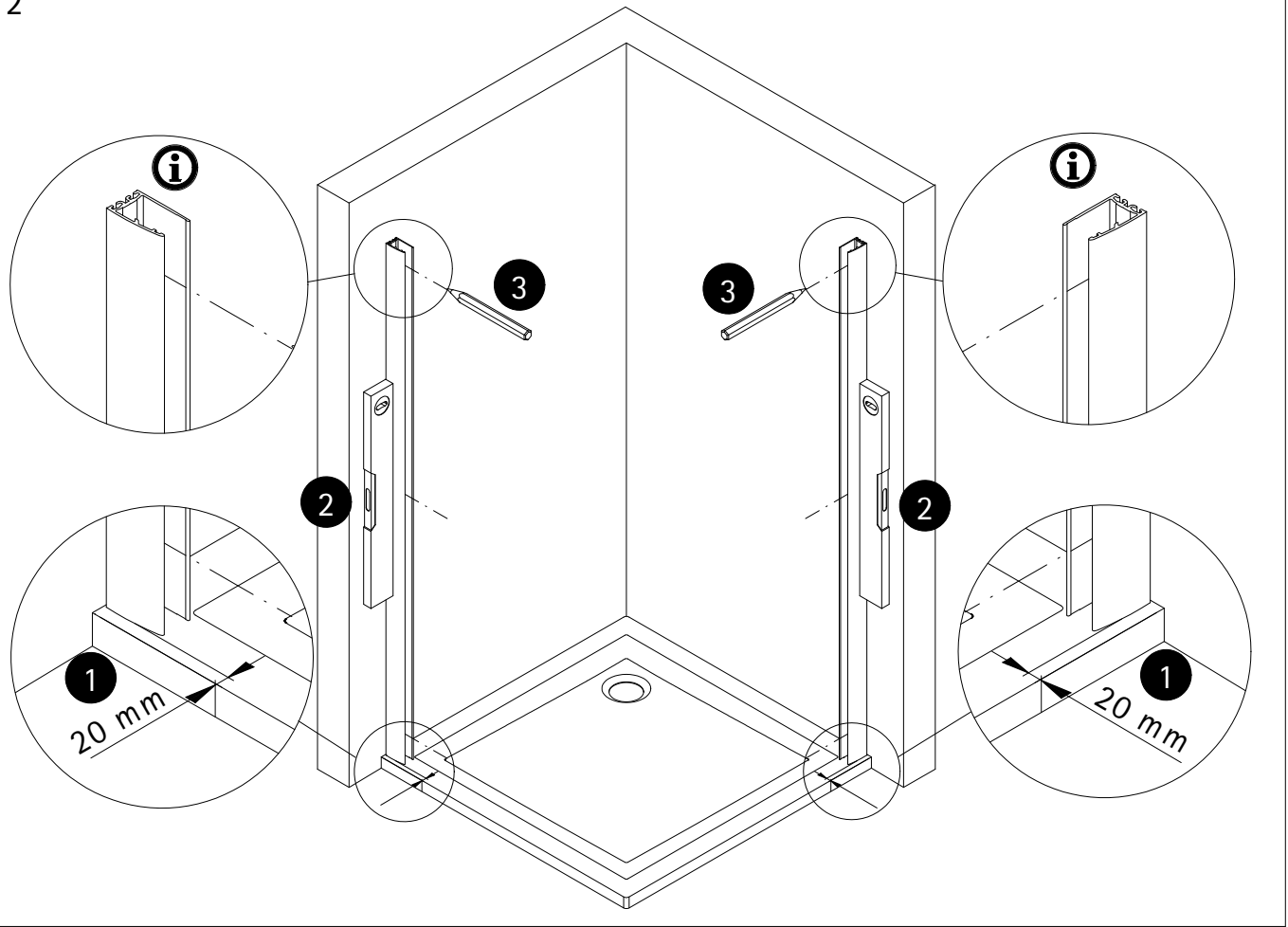

3

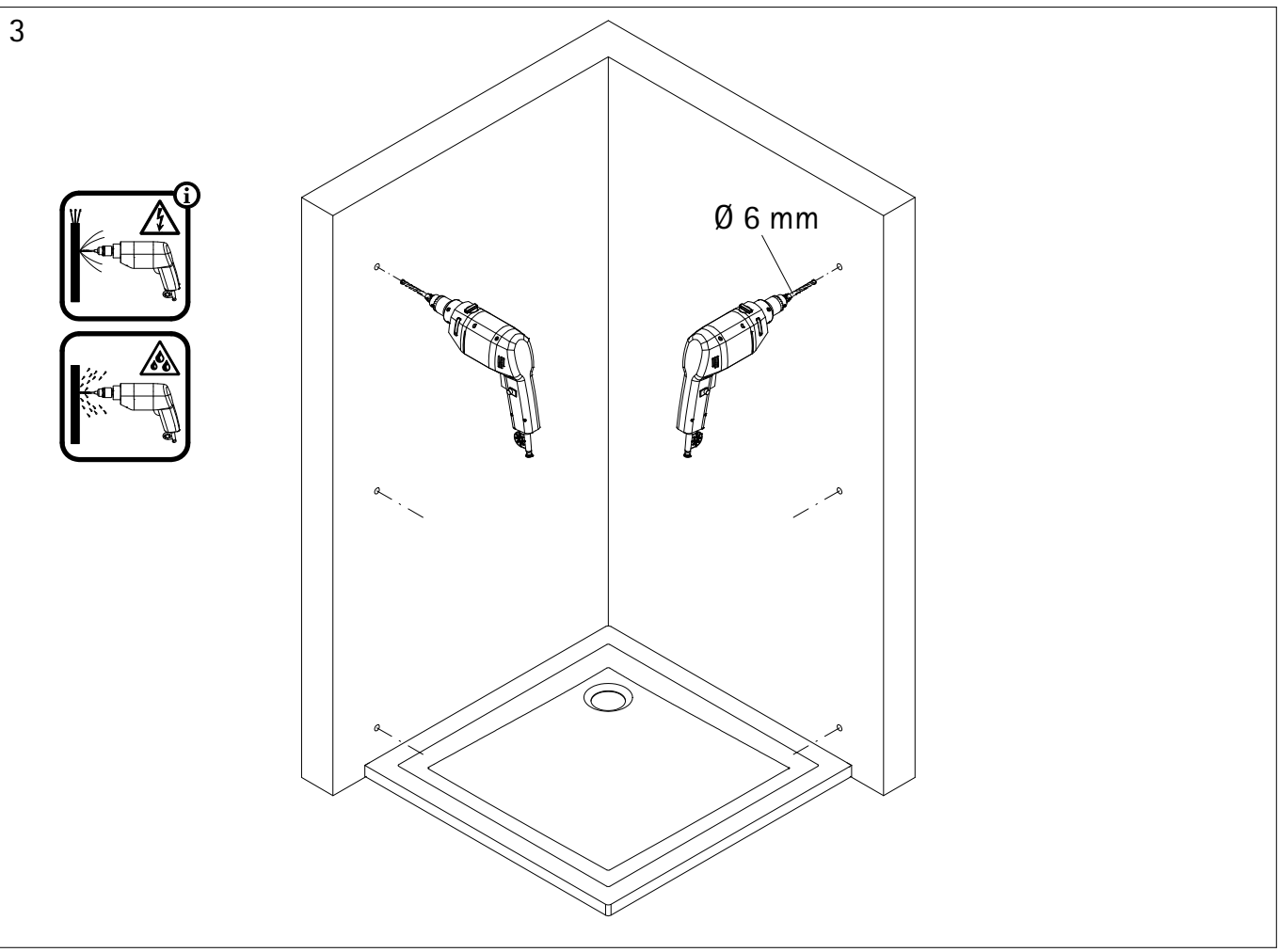

4

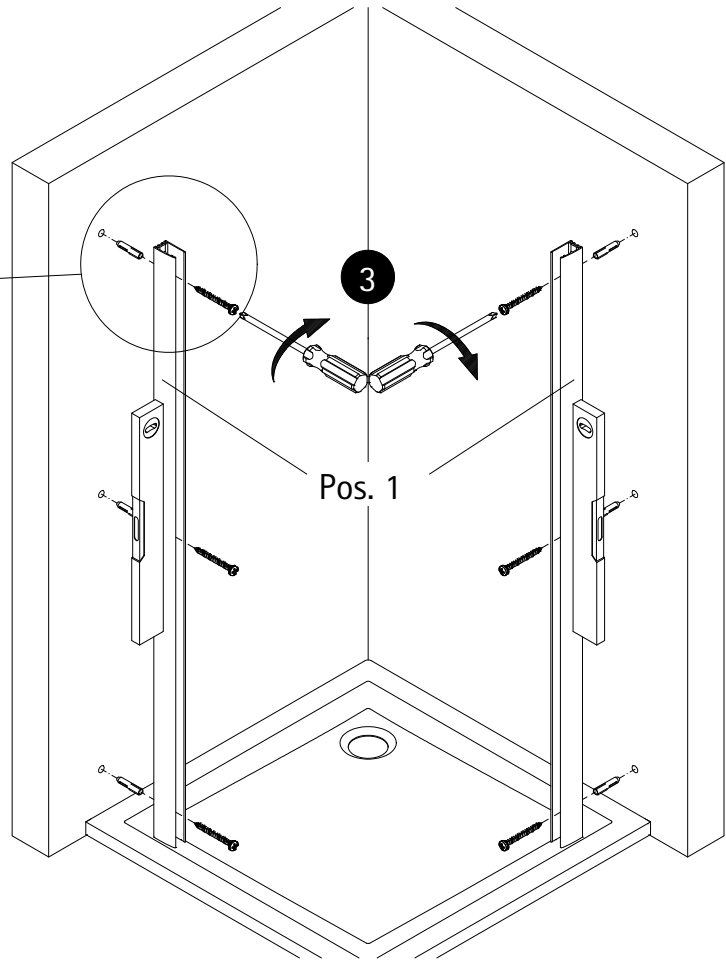
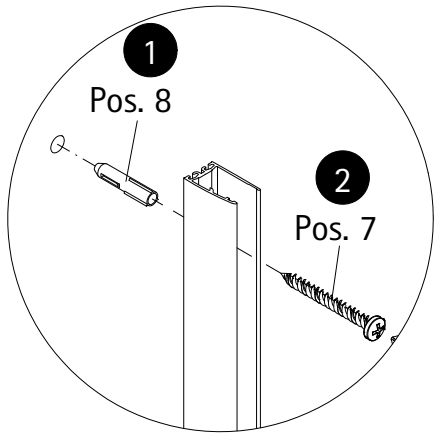

5

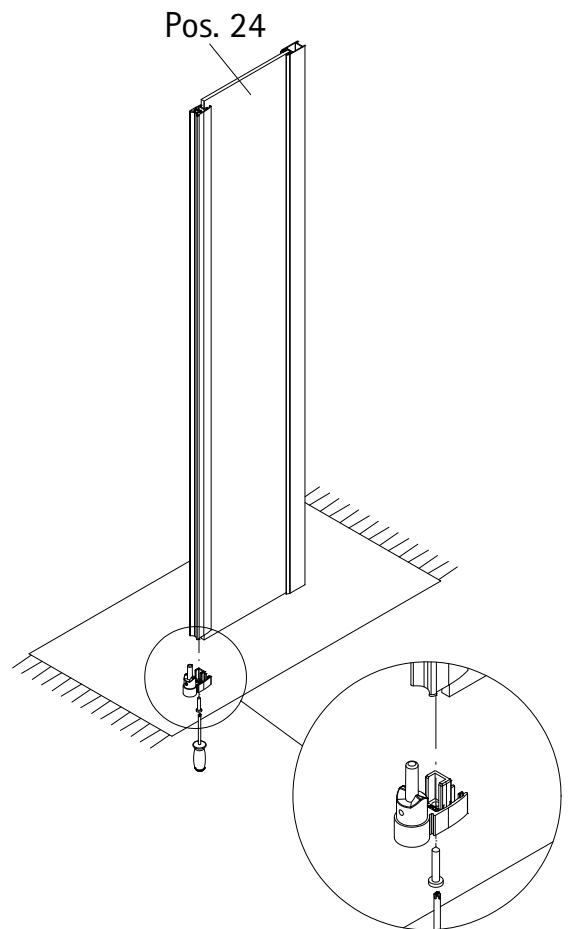
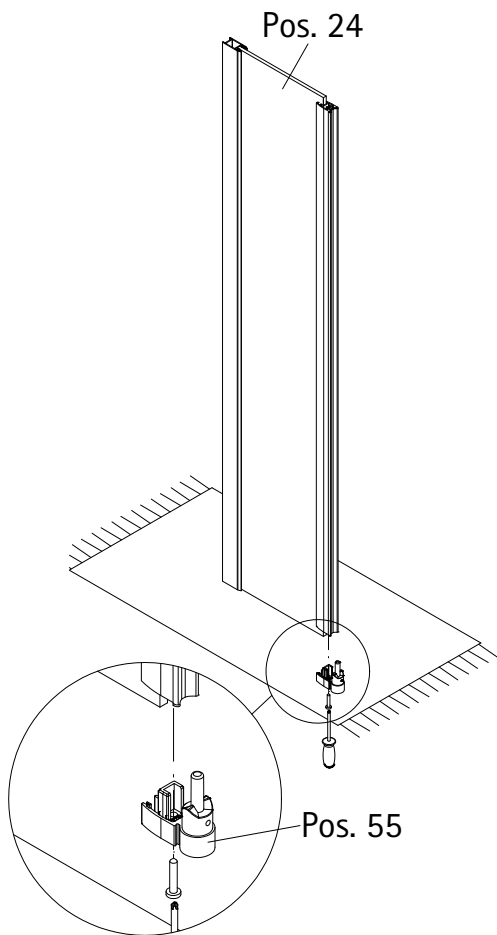

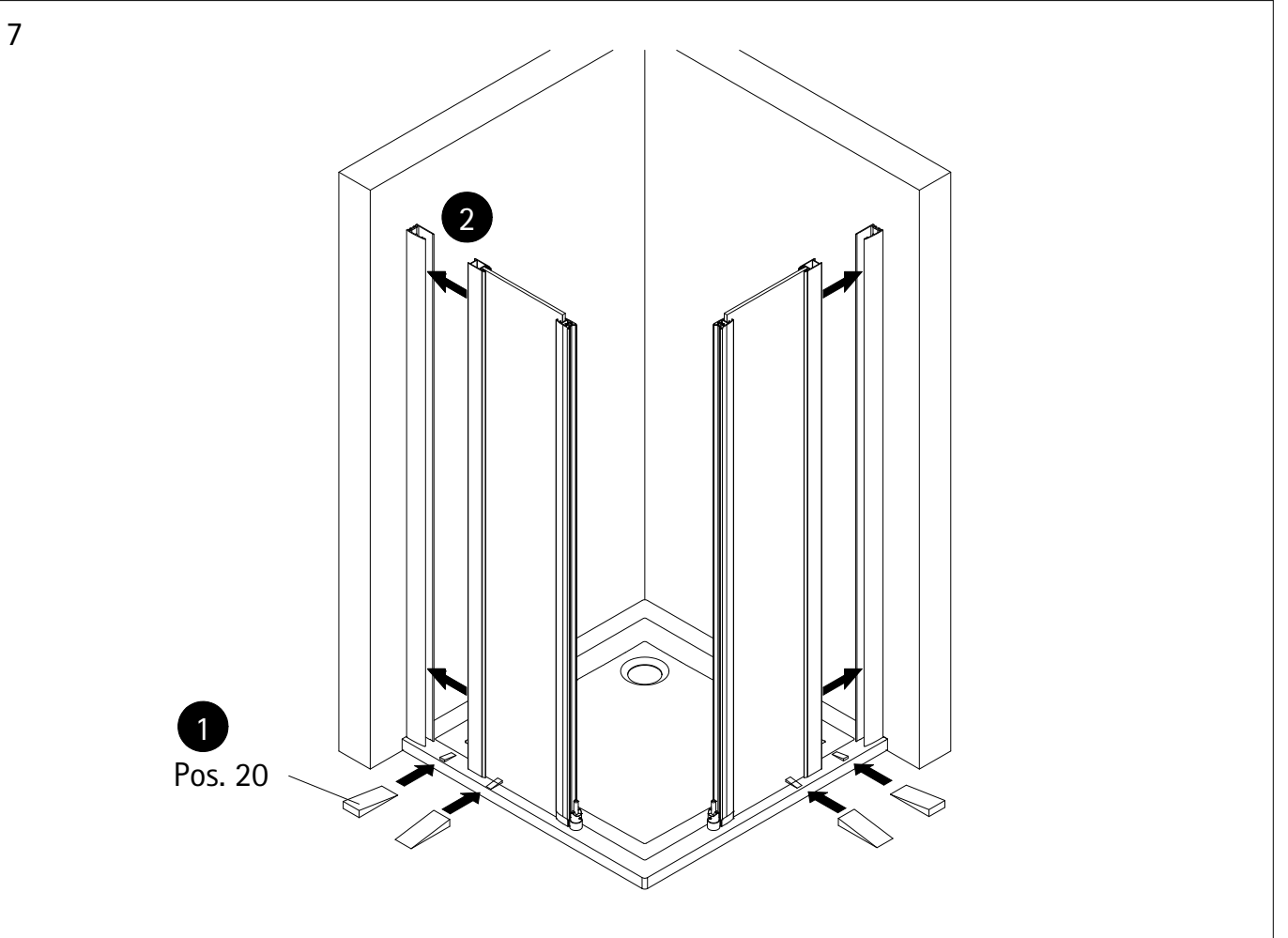
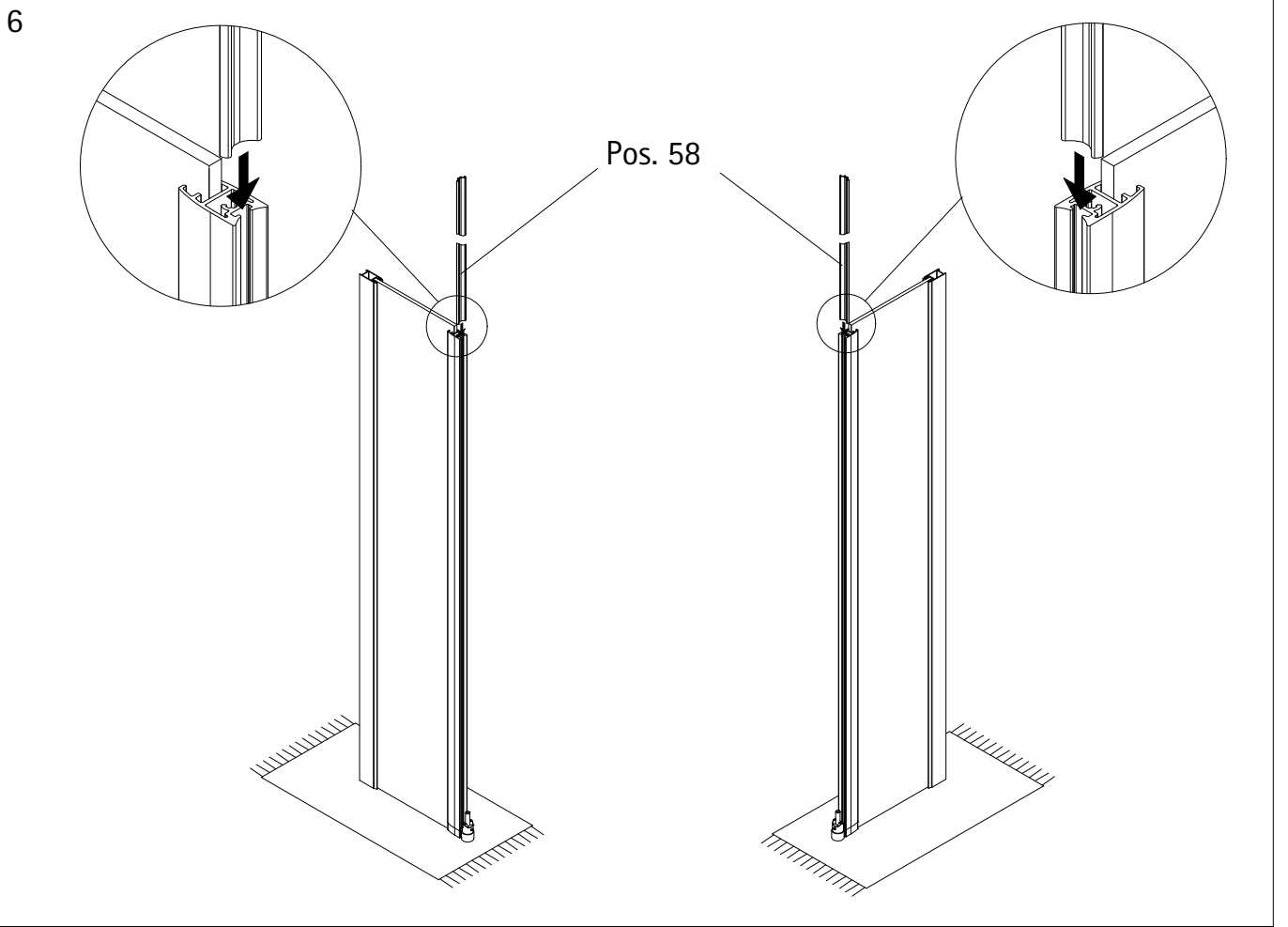

8

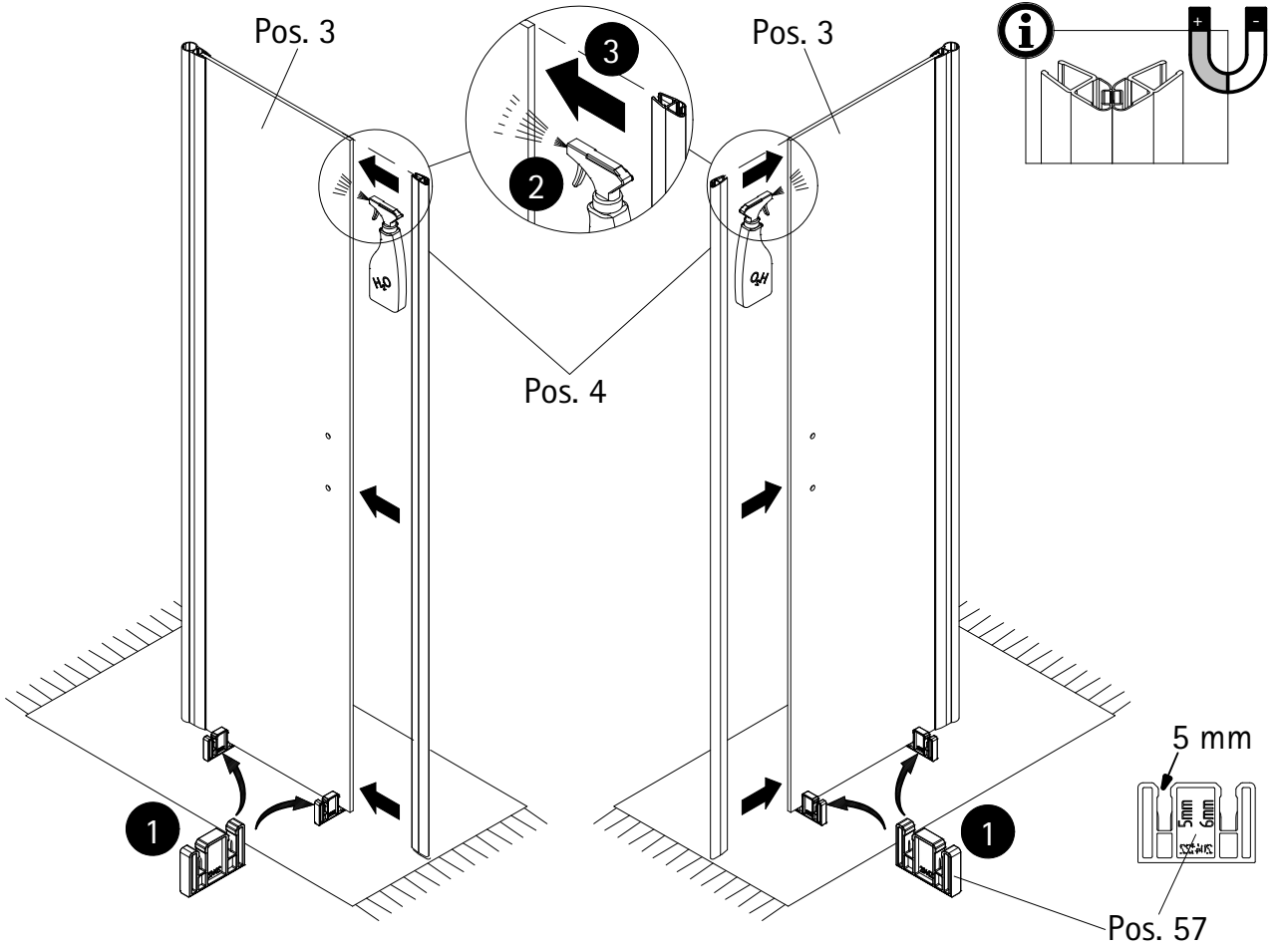

9

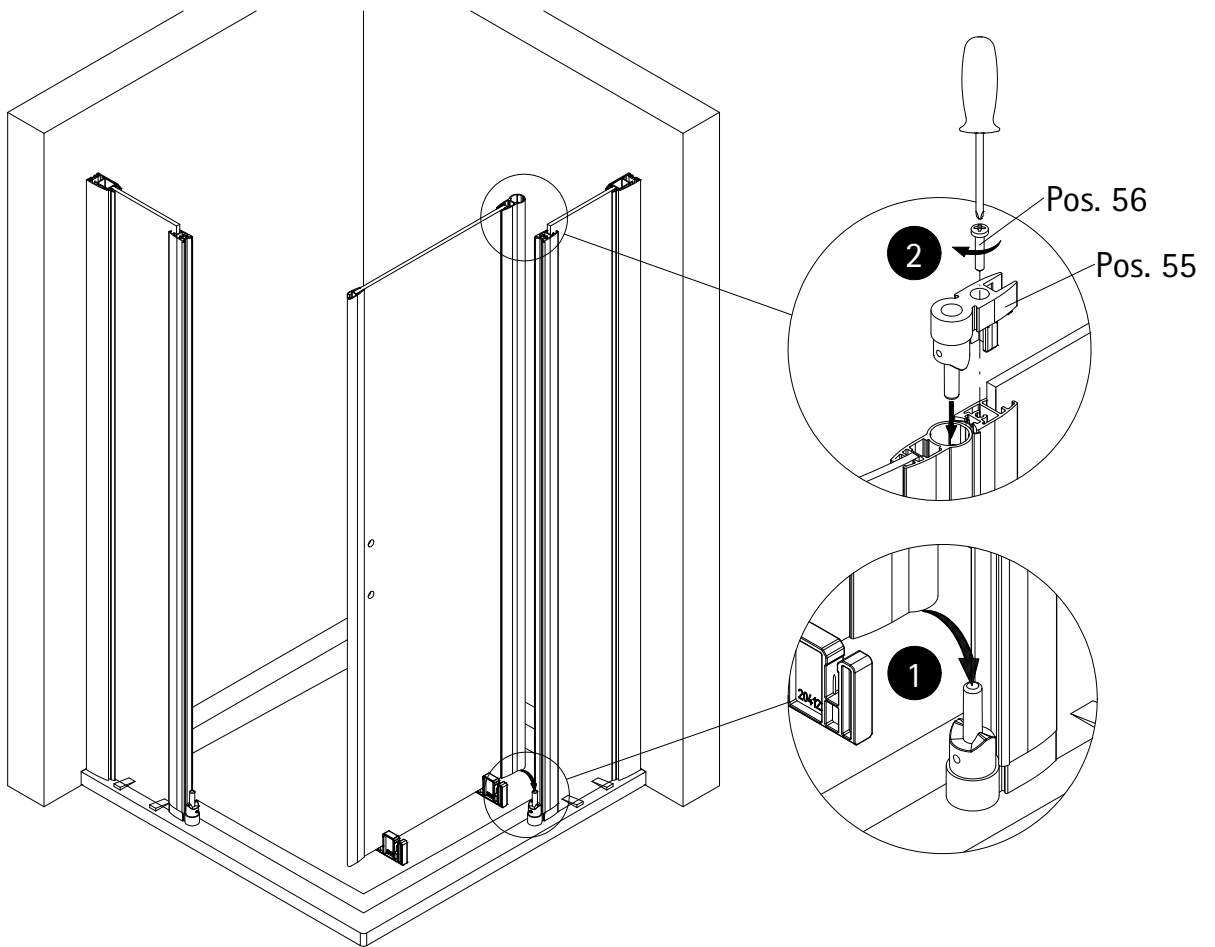

10

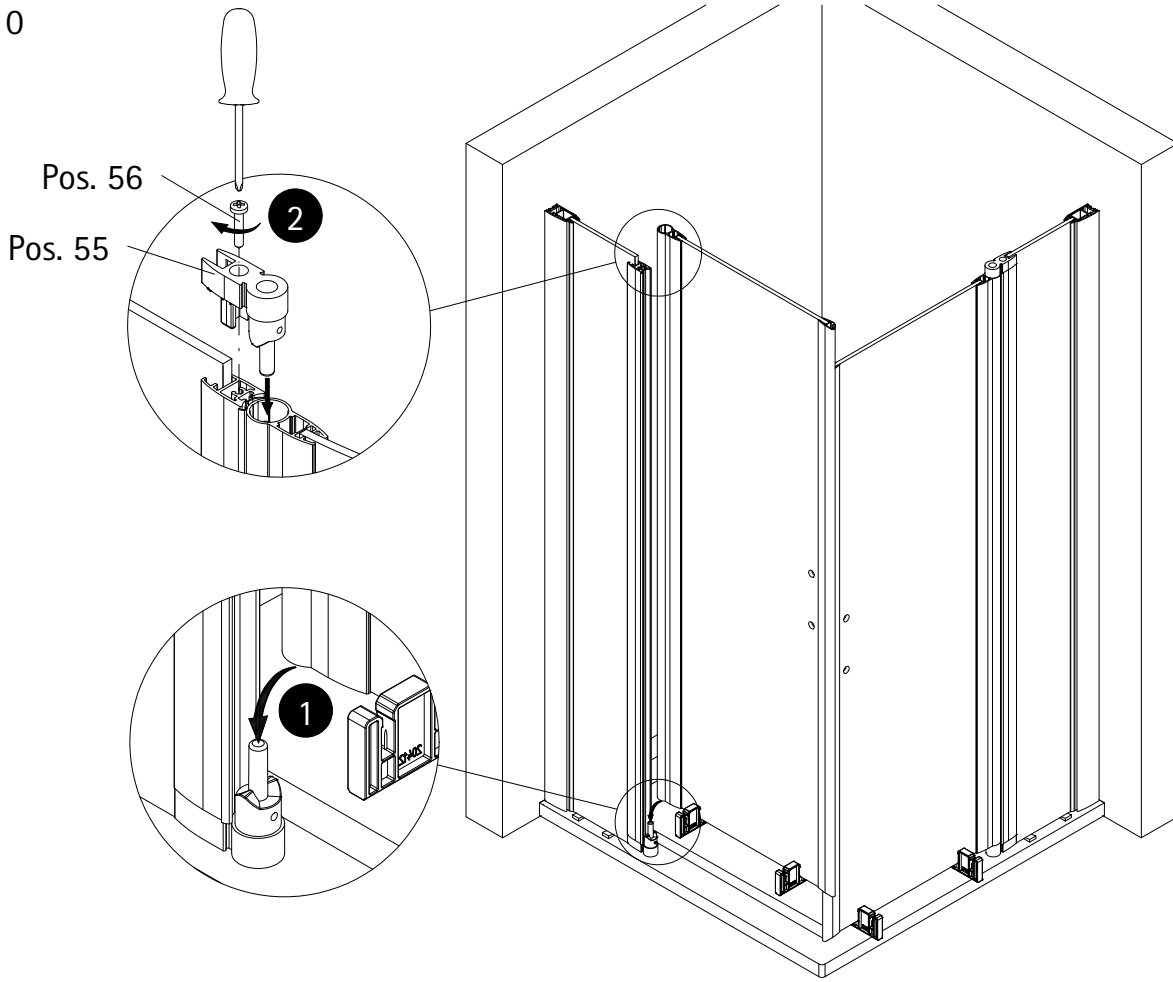

11

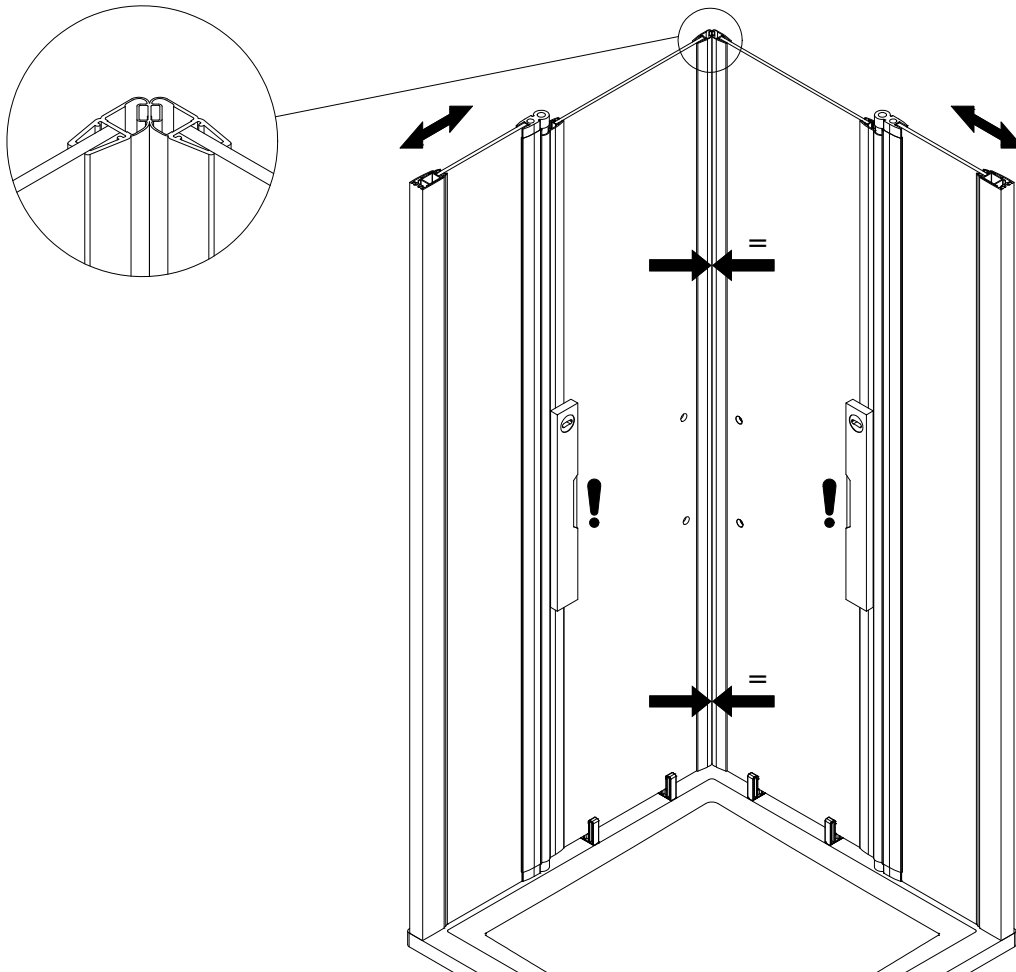

12

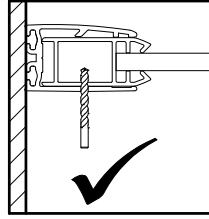
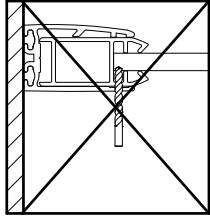

1
Ø 3 mm

2
Pos. 10

3
Pos. 9

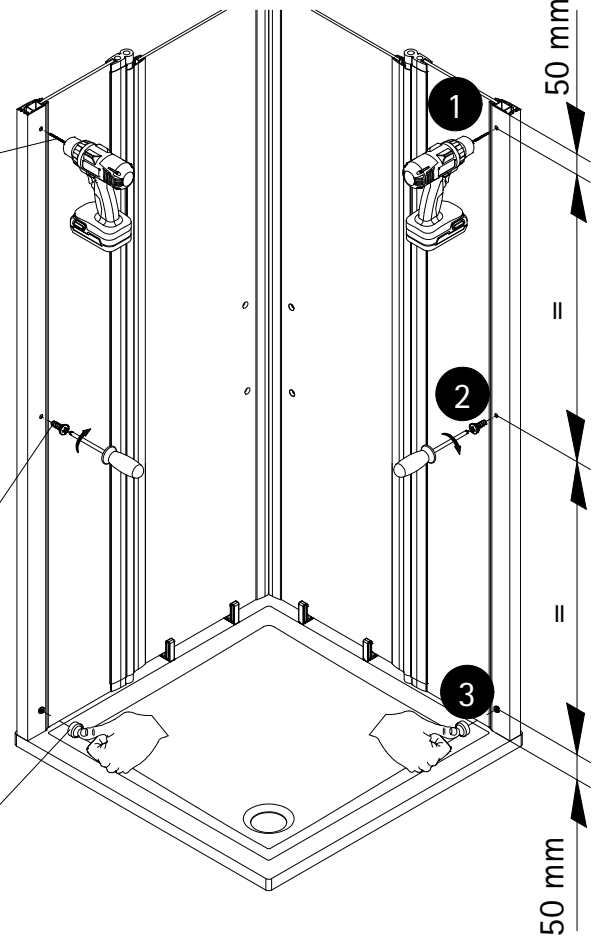

13

Pos. 28

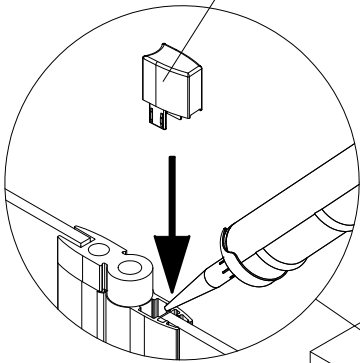

Pos. 28

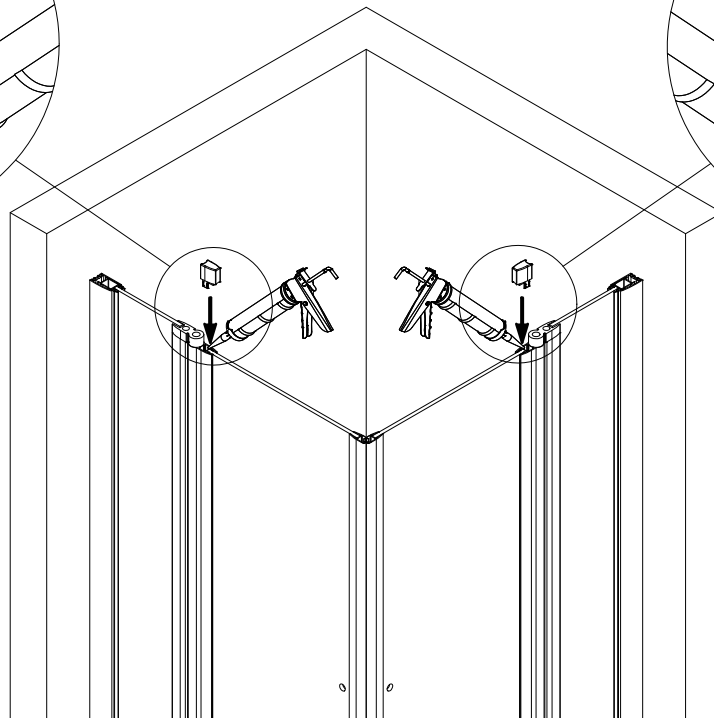
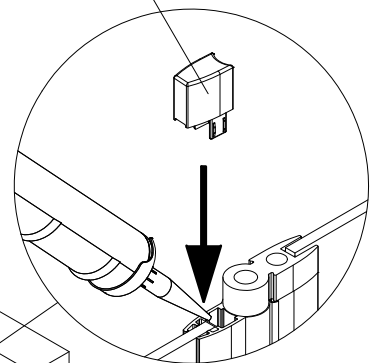

14

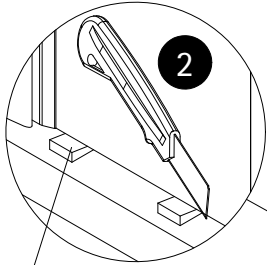

Pos. 20

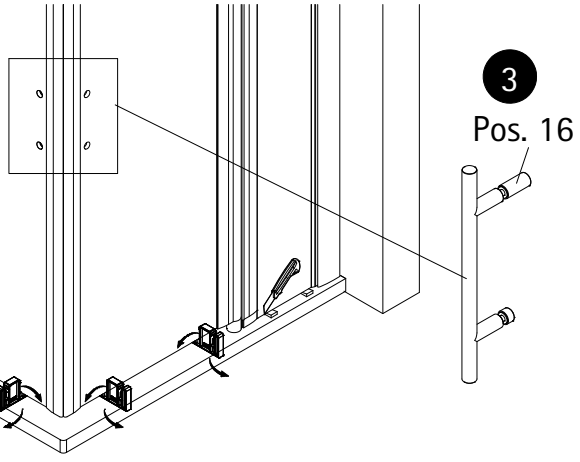
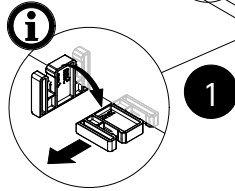

3

Pos. 16

15

Option 1

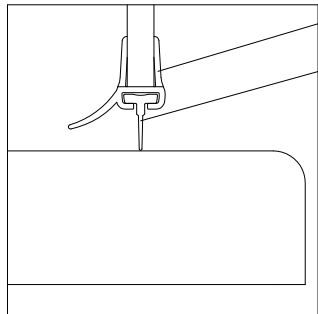

Pos. 11

Pos. 12#

Option 2

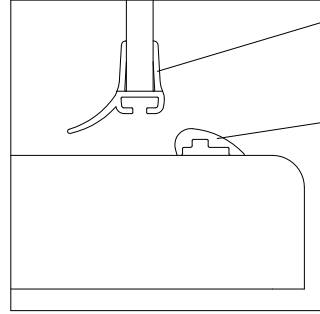

Pos. 11

Pos. 17#

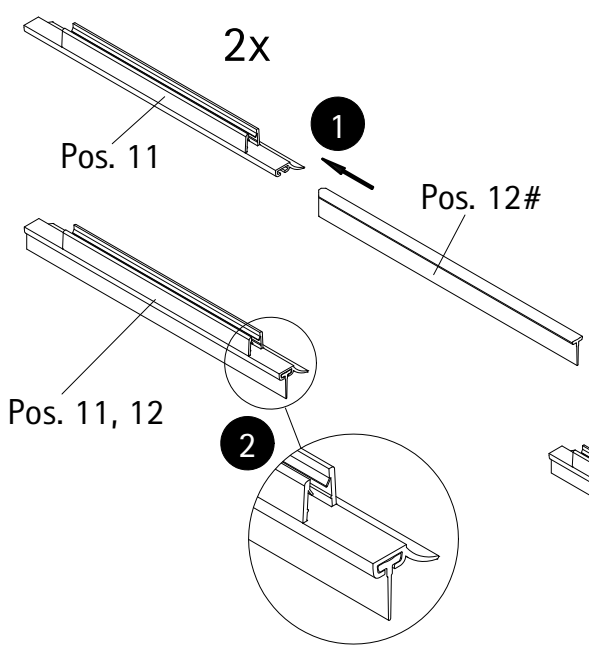

2x

Pos. 11

1

Pos. 12#

Pos. 11, 12

2

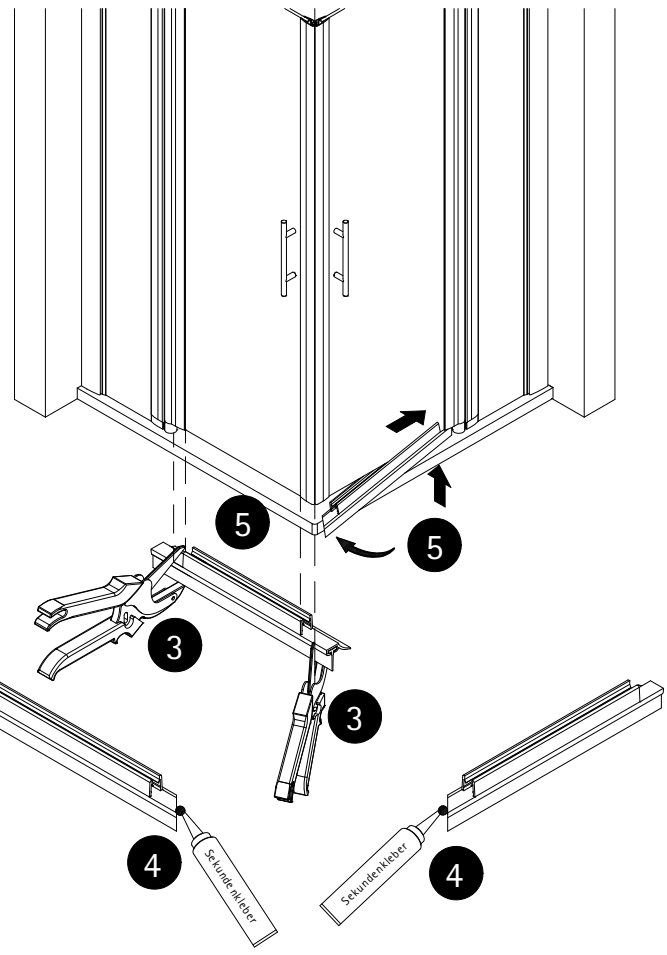

5

5

3

3

4

4

16

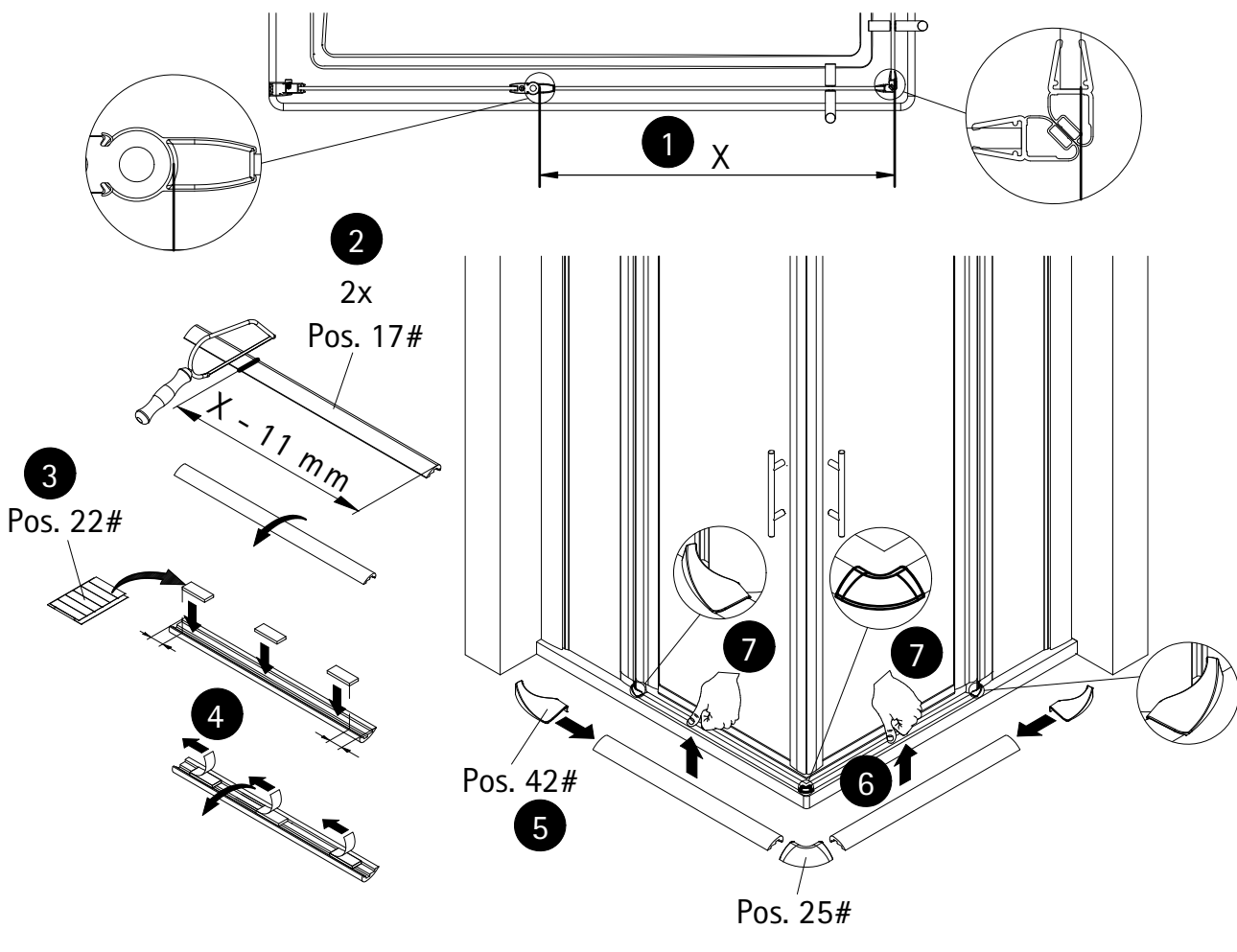

17

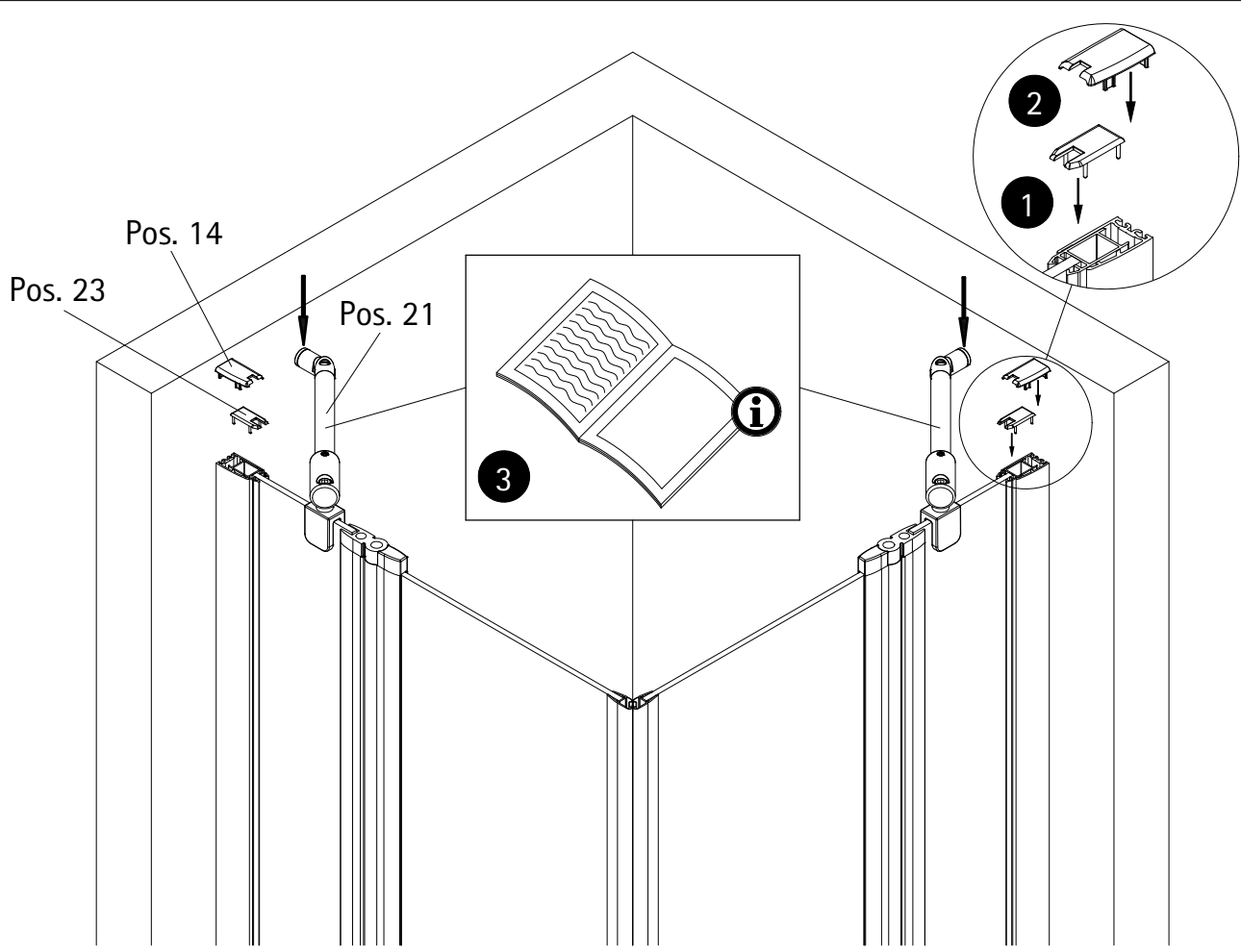

18

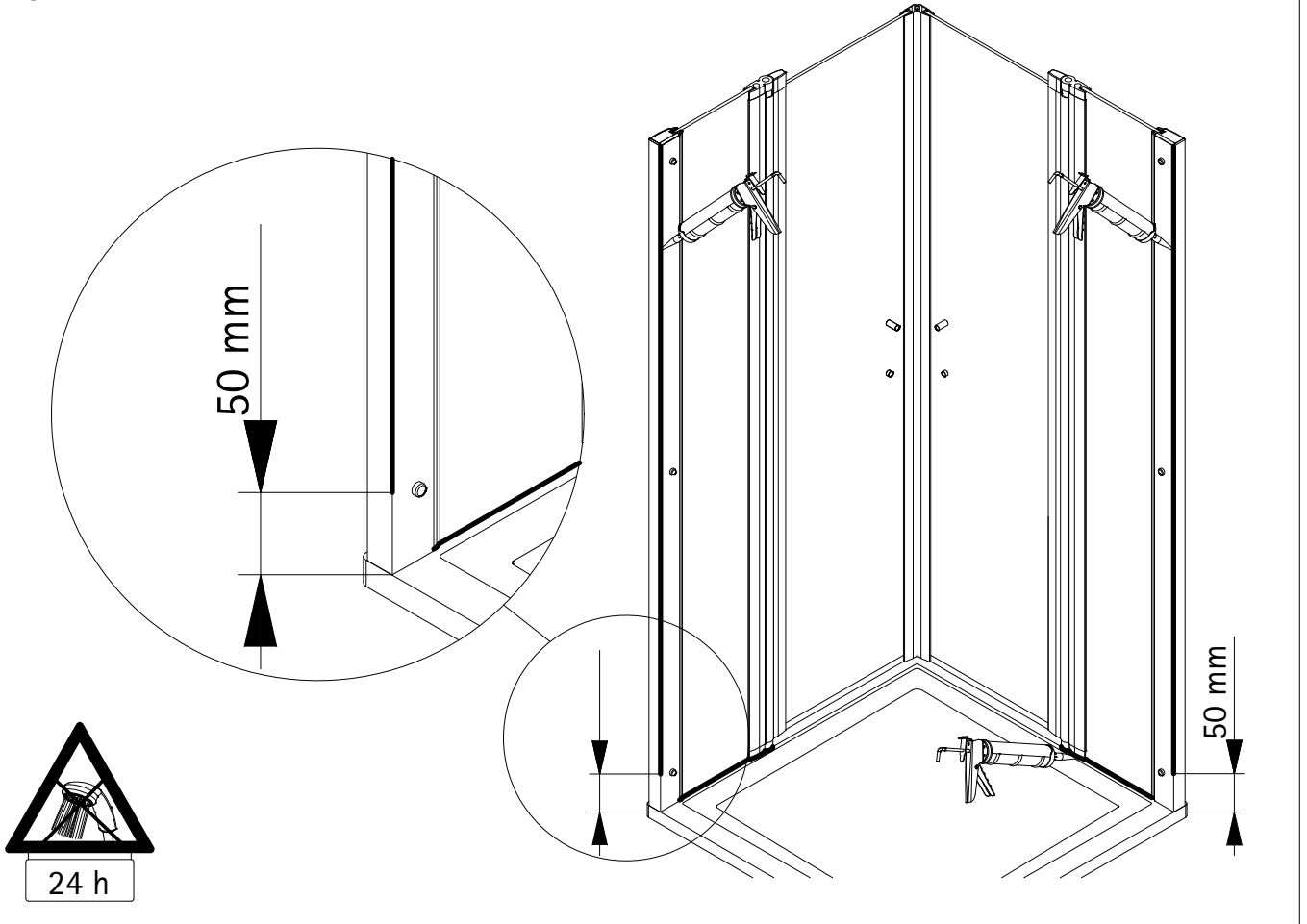

19

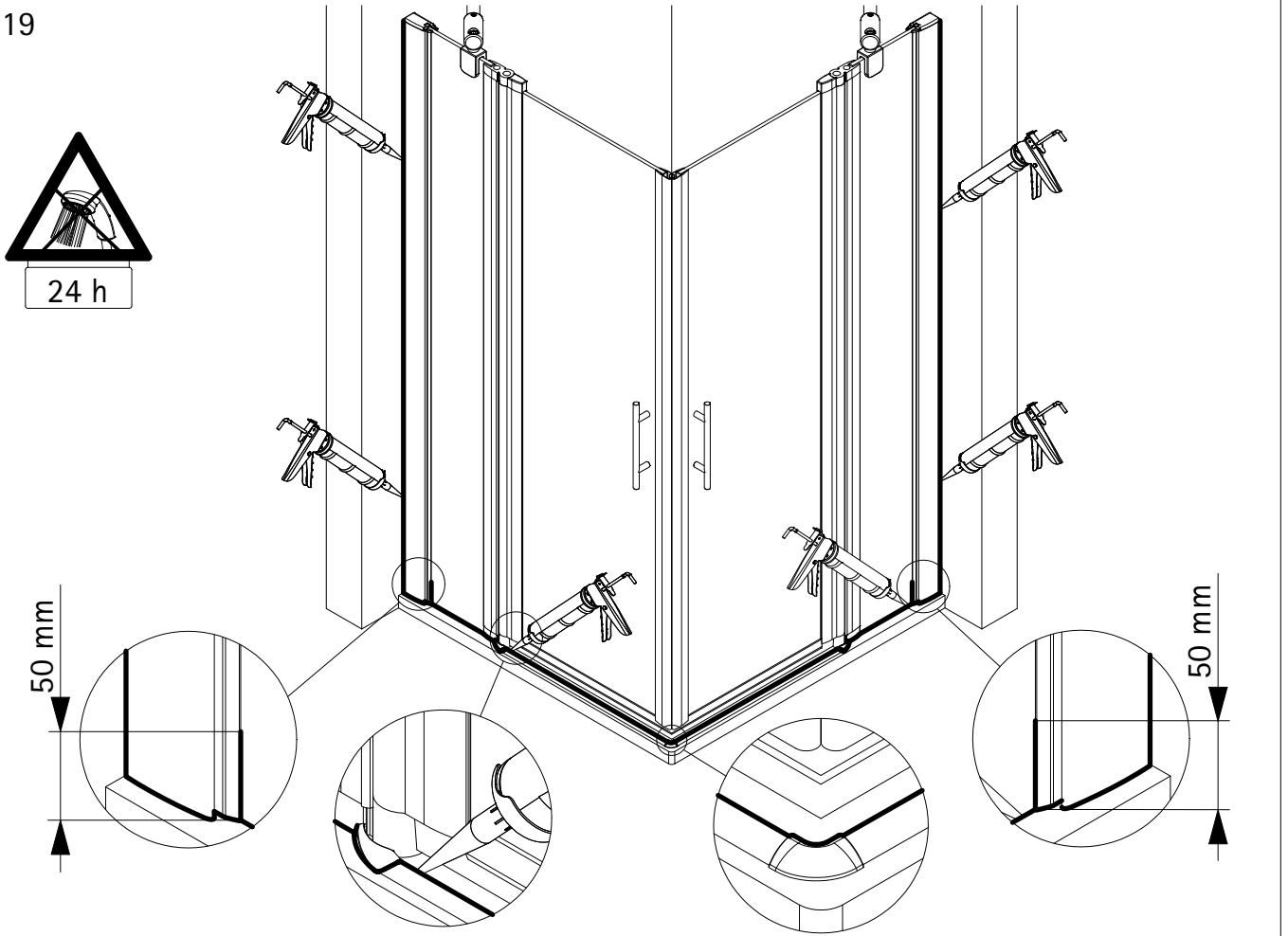

Notizen, notes, notities



1997-3

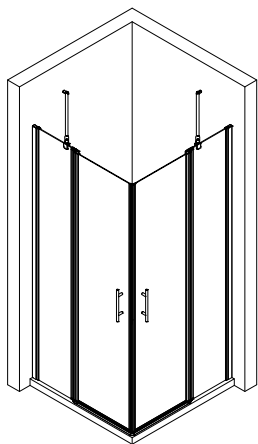

Prüfnummer / Inspection number / Numéro de contrôle / Testnummer



Ersatzteilbestellung / spare parts order
commande de pièces détachées / Bestelling van onderdelen:
Fax 02962 / 972-4260



Technische Hilfe / technical help / l'aide technique / technologische ondersteuning
Telefon 02962 / 9724-0



E-Mail:
ersatzteile@duschservice.de



Duschservice
Zum Hohlen Morgen 22
59939 Olsberg
Deutschland / Germany / Allemagne / Duitsland



00007277500000000000000000